



Scan Engineering

An Oil & Gas Based Company

Exceptional Customer Service For All!



About us

Established in 2006, With 14 years of experience we are meeting the most demanding sheet metal, Stainless steel or Beats application, We provide one step process engineering, programming, machining, forming, special process, assembly to finished products thus enhancing your competitive edge. Share us your idea.

The main objective and most valuable asset Scan Engineering man resources. We take pride in having a committed team of managers supported by innovative engineers and in industrious ad disciplined work force. We recognize the importance of the role our human resource plays in the performance of the manufacturing industries.

Quality & HSE Focus

International certifications and standards to the credit of Scan Engineering endorse its commitment to high quality and ethical standards. The facility is certified to ISO 9001:2015, ISO 14001:2015, ISO 45001: 2018. In addition, Scan Engineering has the, re-certification and manufacture of standard API products in the Middle East.

Scan Engineering is committed to the health and safety of its employees by developing safe procedures, awareness through training and providing protective equipment, conforming to the various services that it offers.

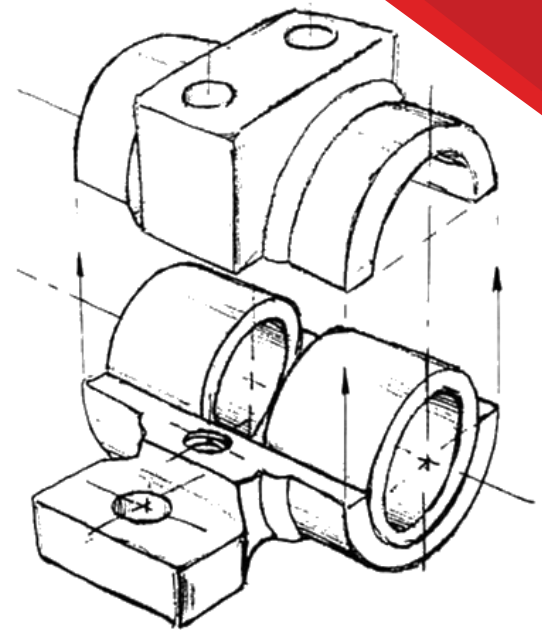

Our Accreditations



Our Services

- **Steel Fabrication & Welding**

We custom fabricate steel parts. Our capabilities include Flame Laser Cutting, Forming, Tube Bending, Welding, Hydraulic Press up to 100 tons, CNC Cutting Machine, CNC Bending Machine, Punching Machine.

Our Welding Shop has various processes to cater to different applications and material, with TPI certified Welders

Tungsten Inert Gas Welding, Metal Inert Gas Welding, Plasma Transferred Arc & Fusion Welding.



- **Product Designing & Development.**



Scan Engineering is a full-service industrial design & mechanical engineering company which develops innovative products for a wide diversity of clients. We create beautiful, distinctive & meaningful products with an eye for sustainability and affordability. We deliver high-quality production ready designs and can assist you with manufacturing, branding & also market introduction.



- **Conventional Machining Works.**

With over 14 years of experience, our Industry Services Division specializes in manufacturing parts to precise specifications using conventional machining capabilities. In addition, we are now concentrating on all Printing Press Machine Maintenances & Services.

(Turning Lathe, Milling, Drilling, slotting, Horizontal Boring, Surface Grinding, Cylindrical Grinding, Bandsaw).

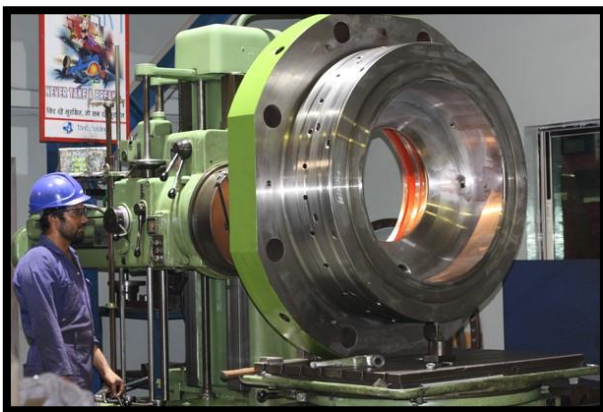

Our Services

- **Manufacturing of Onshore & Offshore Skids**

The Manufacturing & Testing Facilities of Scan Engineering are well Equipped to undertake the most specialized Fabrication Jobs in Transfer Pump, Air Compressor, Bug Blower, Winch unit, Wilden Pump, Container Reworks (INTERIOR & EXTERIOR), Blow lines Projects etc.

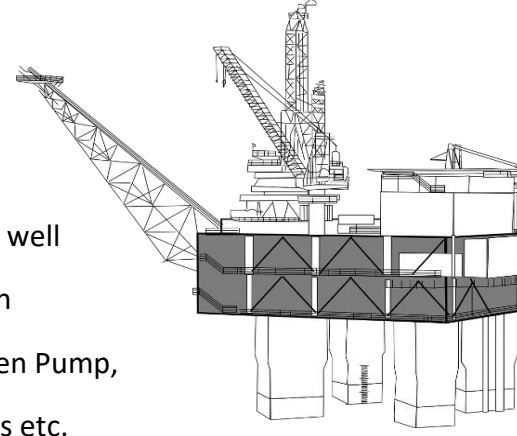

Our Product Range

- Storage Racks,
- Skids for Oil Fields,
- Conveyors,
- Blowers,
- Hopper Feeder,
- Blowlines,
- Heat Plate Exchanger,
- Crossovers,
- Powerpack Modification,
- Wire Drum,
- Container Reworks etc.

Our beloved Customers



02-6427760,0508186710

info@scanengineering.ae



www.scanengineering.ae



@scanengineering



M 39, ABU DHABI, U.A.E.